

Write your name here

Surname

Other names

Pearson Edexcel
International
Advanced Level

Centre Number

--	--	--	--	--

Candidate Number

--	--	--	--

Physics

Advanced Subsidiary

Unit 1: Physics on the Go

Monday 11 January 2016 – Morning
Time: 1 hour 30 minutes

Paper Reference

WPH01/01

You must have:
Ruler

Total Marks

Instructions

- Use **black** ink or ball-point pen.
- **Fill in the boxes** at the top of this page with your name, centre number and candidate number.
- Answer **all** questions.
- Answer the questions in the spaces provided
– *there may be more space than you need.*

Information

- The total mark for this paper is 80.
- The marks for **each** question are shown in brackets
– *use this as a guide as to how much time to spend on each question.*
- Questions labelled with an **asterisk** (*) are ones where the quality of your written communication will be assessed
– *you should take particular care with your spelling, punctuation and grammar, as well as the clarity of expression, on these questions.*
- The list of data, formulae and relationships is printed at the end of this booklet.
- Candidates may use a scientific calculator.

Advice

- Read each question carefully before you start to answer it.
- Keep an eye on the time.
- Try to answer every question.
- Check your answers if you have time at the end.

Turn over ►

P46951A

©2016 Pearson Education Ltd.

1/1/1/1/



PEARSON

SECTION A

Answer ALL questions.

For questions 1–10, in Section A, select one answer from A to D and put a cross in the box . If you change your mind, put a line through the box and then mark your new answer with a cross .

- 1 Physical quantities are either scalars or vectors.

Select the row of the table which correctly identifies a scalar quantity and a vector quantity.

	Scalar	Vector
<input type="checkbox"/> A	force	velocity
<input type="checkbox"/> B	mass	time
<input type="checkbox"/> C	time	force
<input type="checkbox"/> D	velocity	mass

(Total for Question 1 = 1 mark)

- 2 A car is towed by a truck using a rope. The car is pulled at a constant speed creating a tension T in the rope.

The horizontal forces acting on the car are shown.

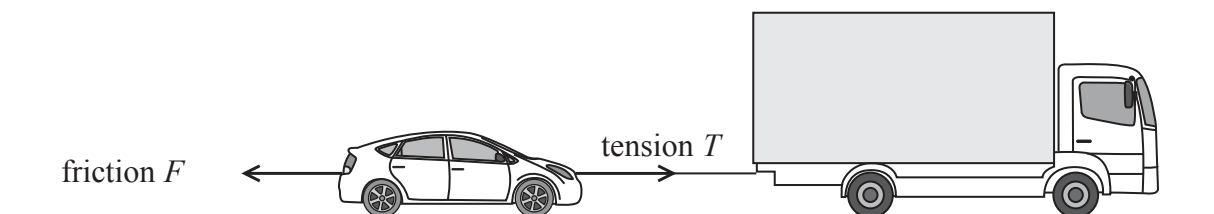

The magnitude of the force exerted by the truck on the car is

- A $T + F$
 B $T - F$
 C T
 D zero

(Total for Question 2 = 1 mark)

DO NOT WRITE IN THIS AREA

DO NOT WRITE IN THIS AREA

DO NOT WRITE IN THIS AREA



DO NOT WRITE IN THIS AREA

DO NOT WRITE IN THIS AREA

DO NOT WRITE IN THIS AREA

3 A girl dropped a stone into an empty well. She heard the sound of the stone hitting the bottom of the well after 4 seconds.

The depth of the well is about

- A 20 m
- B 40 m
- C 80 m
- D 160 m

(Total for Question 3 = 1 mark)

4 Select the row of the table that correctly matches the property of a material to the type of deformation it can experience.

	Property	Elastic deformation	Plastic deformation
<input type="checkbox"/> A	brittle	no	yes
<input type="checkbox"/> B	brittle	yes	little or no
<input type="checkbox"/> C	malleable	no	yes
<input type="checkbox"/> D	malleable	yes	little or no

(Total for Question 4 = 1 mark)

5 The gravitational field strength on Jupiter is 2.6 times greater than the gravitational field strength on Earth.

The weight of 10 kg of matter on Jupiter would be approximately

- A 26 N
- B 38 N
- C 98 N
- D 260 N

(Total for Question 5 = 1 mark)



- 6 A spring of length 5.0 cm is suspended from a retort stand. When a mass of 0.030 kg is added the length of the spring doubles.



0.030 kg

The energy stored in the stretched spring can be calculated using

- A $\frac{1}{2} \times 0.030 \times 9.81 \times 0.10^2$
- B $\frac{1}{2} \times 0.030 \times 9.81 \times 0.10$
- C $\frac{1}{2} \times 0.030 \times 9.81 \times 0.050^2$
- D $\frac{1}{2} \times 0.030 \times 9.81 \times 0.050$

(Total for Question 6 = 1 mark)

- 7 A student takes measurements for a piece of copper wire.

Mass	0.00500 kg
Length	3.36 m
Diameter	0.00046 m

The student uses these values to calculate a value for the density of copper. The correctly calculated value of density is shown on the student's calculator as

8954.166841

The student should state the density as

- A 8954.166841 kg m⁻³
- B 8950 kg m⁻³
- C 8.95×10^3 kg m⁻³
- D 9.0×10^3 kg m⁻³

(Total for Question 7 = 1 mark)



Questions 8 and 9 refer to the graphs and information below.

A force is applied to a spring and the spring extends. The new length of the spring is recorded.

This procedure is repeated for different applied forces.

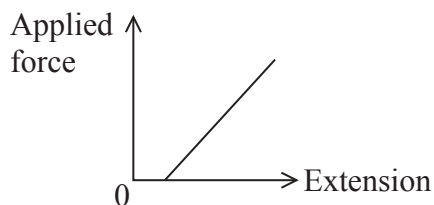

P

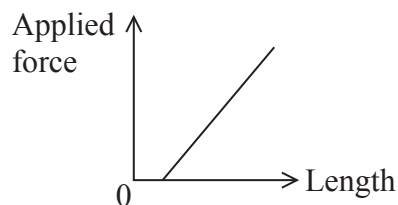

Q

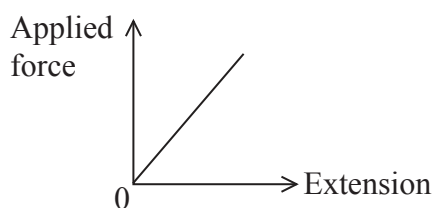

R

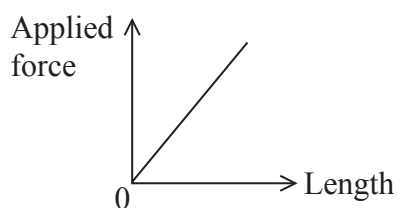

S

8 Which of the above graphs could be obtained from this experiment?

- A** P and Q
- B** P and S
- C** R and Q
- D** R and S

(Total for Question 8 = 1 mark)

9 The graphs could show that the spring is

- A** obeying Hooke's law.
- B** extending plastically.
- C** extended beyond the limit of proportionality.
- D** being compressed as well as extended.

(Total for Question 9 = 1 mark)



- 10 A car travels 90 m east then 50 m north. A vector diagram is drawn with a dashed line representing the resultant displacement.

Which is a correct vector diagram for the displacement of the car?

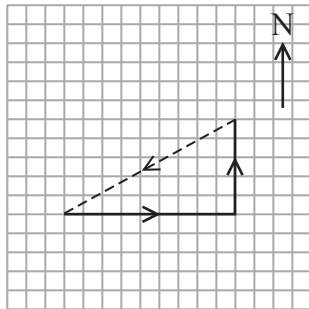

A

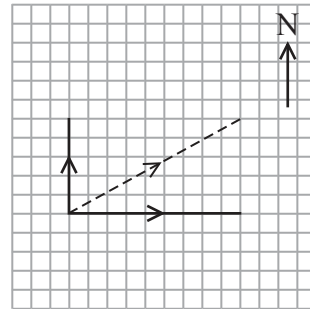

B

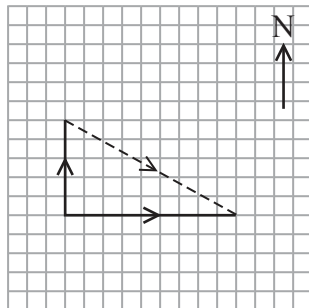

C

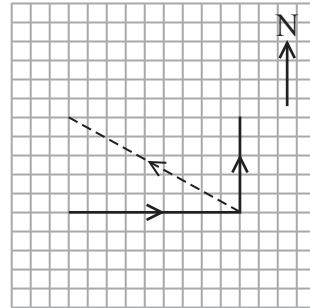

D

(Total for Question 10 = 1 mark)

TOTAL FOR SECTION A = 10 MARKS



DO NOT WRITE IN THIS AREA

DO NOT WRITE IN THIS AREA

DO NOT WRITE IN THIS AREA

SECTION B

Answer ALL questions in the spaces provided.

11 A box of mass 5.0 kg is moved from the ground to a shelf at a height of 1.5 m.

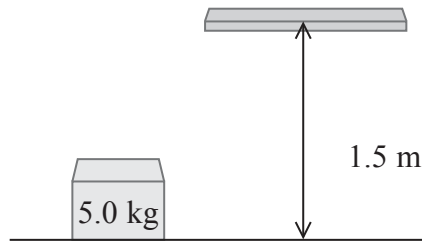

A student is asked to calculate the energy transfer as the height is increased.

The student could use either of the following formulae.

$$\Delta W = F\Delta s \quad \text{or} \quad \Delta E_{\text{grav}} = mg\Delta h$$

(a) Explain how the two formulae are equivalent.

(2)

.....

.....

.....

.....

.....

.....

.....

(b) Calculate the increase in gravitational potential energy of the box.

(2)

.....

.....

.....

.....

Increase in gravitational potential energy =

(Total for Question 11 = 4 marks)



12 A student carried out an experiment to obtain a value for the acceleration of free fall g .

A small ball was dropped from rest and the motion of the ball was captured using a digital camera. The student counted the frames from the recording to measure the time t for the ball to fall to the ground.

A ruler was visible on the recording to enable the student to measure the distance s fallen by the ball.

(a) Use Newton's second law of motion to show that the acceleration of the ball is independent of its mass. (1)

.....

.....

.....

(b) (i) State the equation that the student should use to calculate the value of g . (1)

.....

.....

(ii) A value for g was obtained and was greater than expected.
Explain **one** possible source of error that would have produced a greater than expected value. (2)

.....

.....

.....

.....

.....

(Total for Question 12 = 4 marks)



DO NOT WRITE IN THIS AREA

DO NOT WRITE IN THIS AREA

DO NOT WRITE IN THIS AREA

13 Brass is an alloy made from copper and zinc. The ultimate tensile strength and hardness of brass increase as the zinc content increases.

(a) (i) State what is meant by the term strength. (1)

.....
.....
.....

(ii) State what is meant by the term hardness. (1)

.....
.....
.....

(b) The stress-strain graph for a sample of brass is shown.

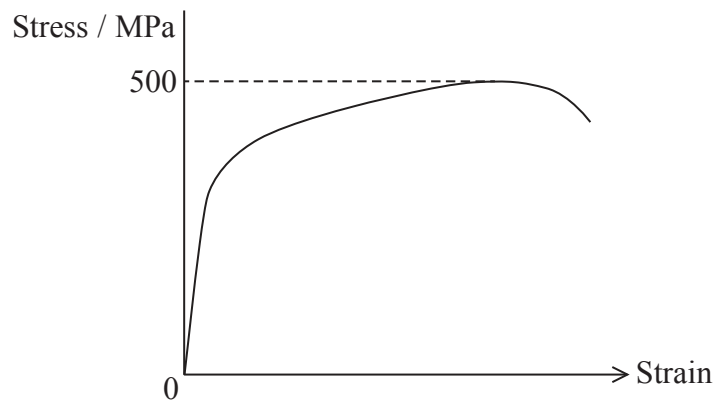

The typical stress when turning a key in a lock is about 10 MPa.

Use information from the graph to suggest why brass is a suitable material for use in keys. (4)

.....
.....
.....
.....
.....
.....
.....
.....
.....

(Total for Question 13 = 6 marks)



*14 The designer of a new lorry trailer claims it will save 10% on the amount of fuel used compared to a traditional trailer.

The photographs show the airflow around a traditional trailer and around the new trailer.



Traditional trailer



New trailer

Using information from the photographs, explain why the new trailer would use less fuel compared to the traditional trailer.

(4)

.....

.....

.....

.....

.....

.....

.....

.....

.....

.....

.....

.....

.....

.....

.....

.....

.....

.....

.....

.....

.....

.....

.....

(Total for Question 14 = 4 marks)



DO NOT WRITE IN THIS AREA

DO NOT WRITE IN THIS AREA

DO NOT WRITE IN THIS AREA

15 (a) Show that a unit for the Young modulus is N m^{-2} .

(2)

.....

.....

.....

(b) A foam cube of side 7.0 cm is compressed.

The cube is compressed with a force of 50 N and the vertical sides are reduced to 5.0 cm in length.

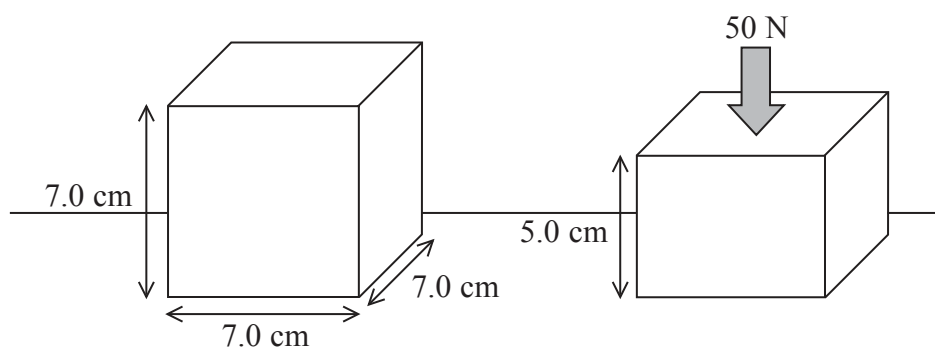

(i) Calculate the Young modulus of the foam. Assume that the other dimensions of the foam do not change.

(3)

.....

.....

.....

.....

Young modulus =

(ii) The assumption in (i) is incorrect.

Explain how this would affect the calculated value of the Young modulus.

(2)

.....

.....

.....

(Total for Question 15 = 7 marks)



16 The toy aeroplane in the photograph has a spring mechanism connected to the wheels. When the aeroplane is pulled backwards, the wheels rotate backwards and a spring is compressed. When the aeroplane is released, the force from the spring propels the aeroplane forwards.



The aeroplane is pulled backwards, released and then moves forward in a straight line along a flat surface. The simplified acceleration-time graph for the forward motion of the aeroplane is shown.

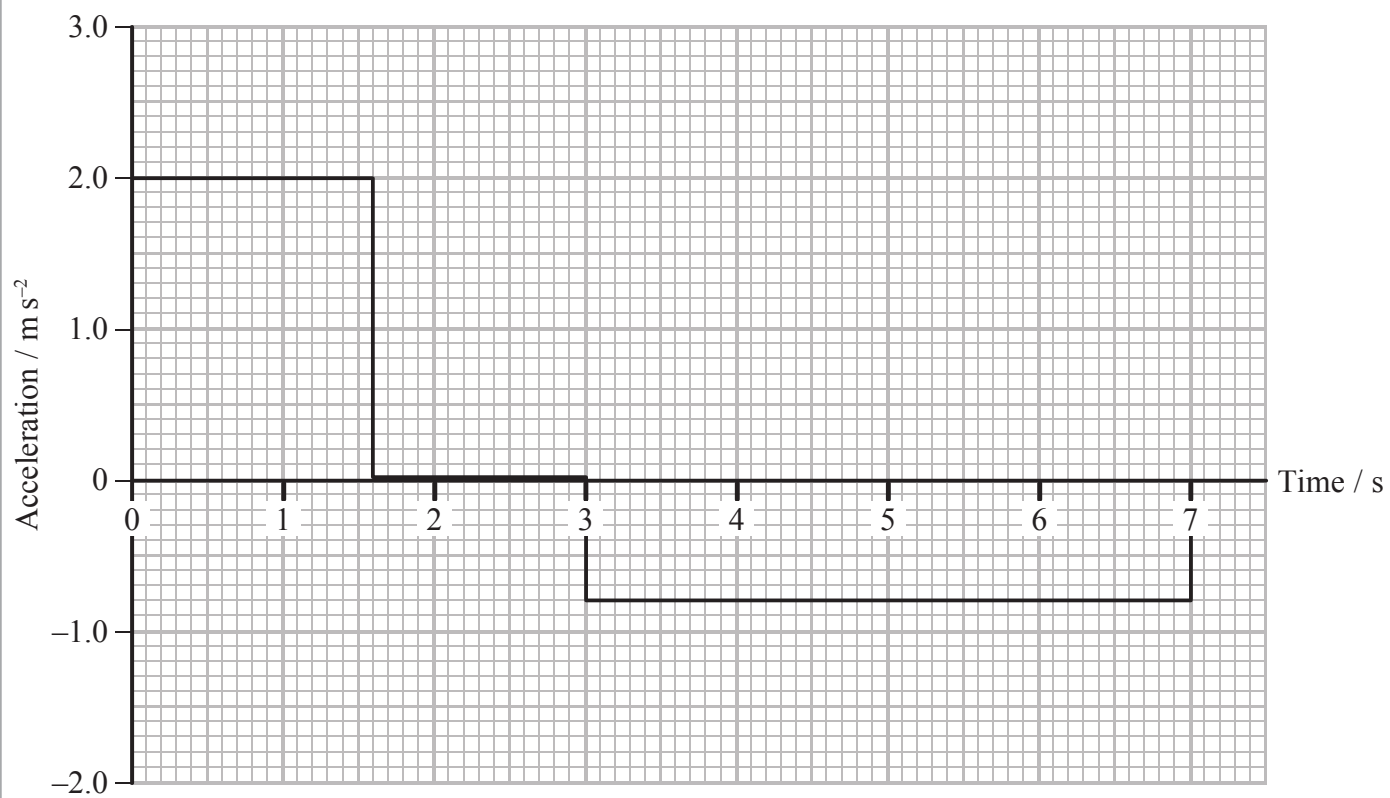

(a) Show that the maximum velocity of the aeroplane is about 3 m s^{-1} . (2)

.....

.....

.....

.....



DO NOT WRITE IN THIS AREA

DO NOT WRITE IN THIS AREA

DO NOT WRITE IN THIS AREA

(b) On the axes below draw the corresponding velocity-time graph for the aeroplane. (3)

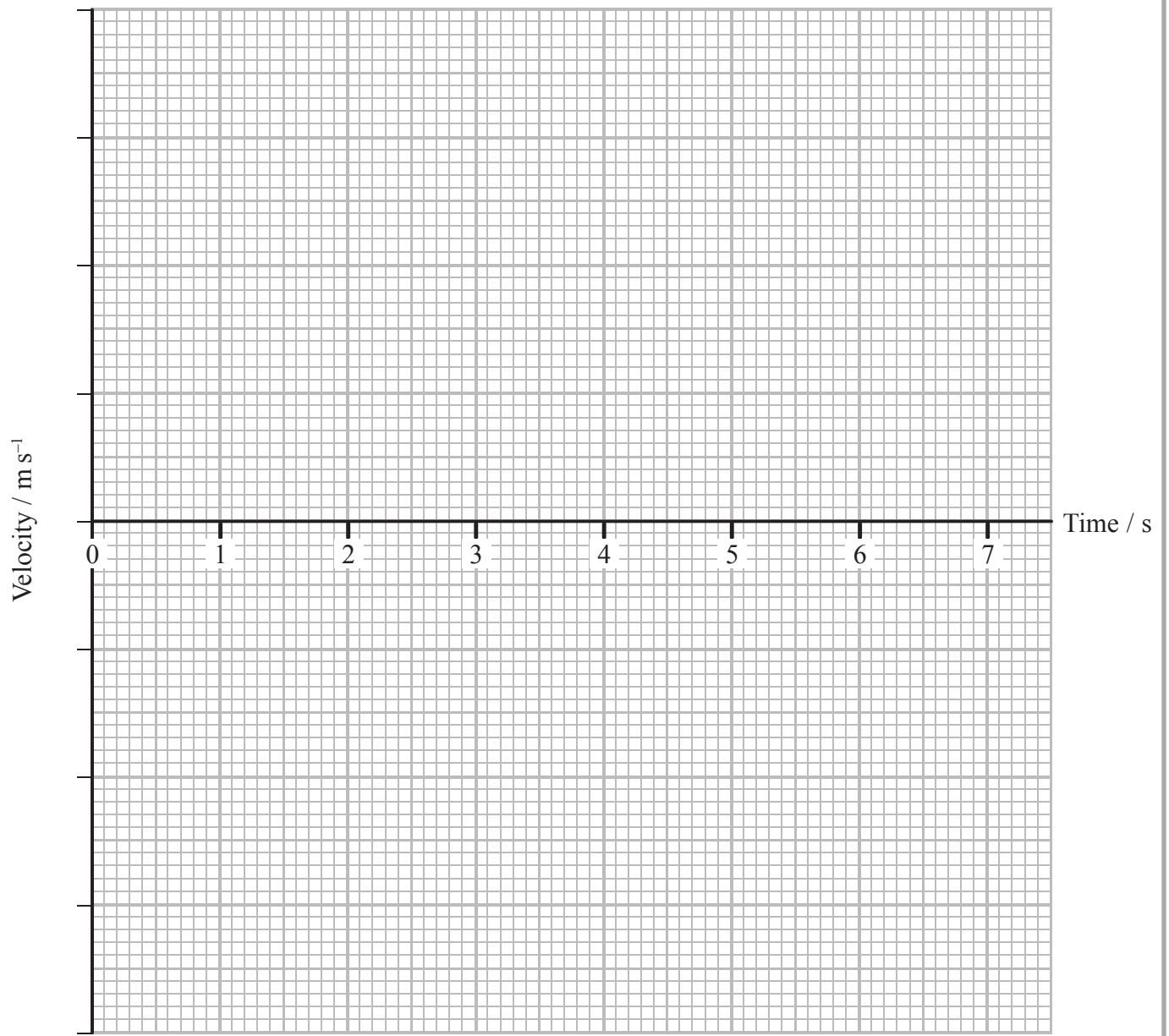

(c) Calculate the total distance travelled by the aeroplane after release. (3)

.....

.....

.....

.....

.....

.....

Total distance travelled =



DO NOT WRITE IN THIS AREA

DO NOT WRITE IN THIS AREA

DO NOT WRITE IN THIS AREA

(d) (i) Calculate the maximum kinetic energy of the aeroplane.

mass of aeroplane = 0.12 kg

(2)

.....

.....

.....

.....

.....

Maximum kinetic energy =

(ii) Calculate the mean power developed by the spring mechanism during the period of acceleration.

(2)

.....

.....

.....

.....

Mean power developed =

(Total for Question 16 = 12 marks)



DO NOT WRITE IN THIS AREA

DO NOT WRITE IN THIS AREA

DO NOT WRITE IN THIS AREA

17 The photograph shows a 'lava lamp'.

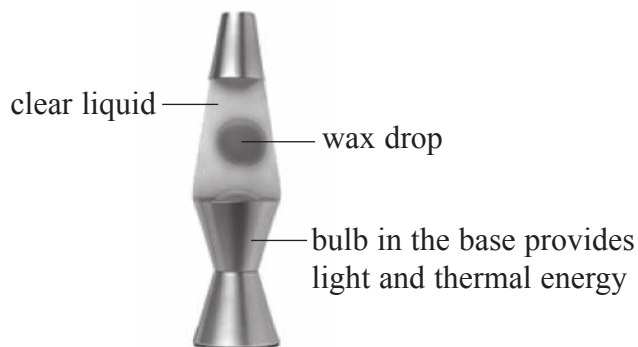

When the lamp is switched on, large drops of liquid wax are seen to rise and then fall within the clear liquid.

(a) As a wax drop is heated it expands, its density decreases and it rises through the clear liquid.

(i) Explain why the wax drop begins to move upwards as it is heated.

(3)

.....

.....

.....

.....

.....

.....

.....

.....

.....

.....

.....

(ii) The wax drop accelerates initially and then reaches a terminal velocity.

Write a word equation for the forces acting on the wax drop when it is moving upwards at its terminal velocity.

(2)

.....

.....

.....

.....



(b) The wax drop is seen to slow down as it reaches the top of the lamp.

Explain this observation.

(3)

.....

.....

.....

.....

.....

.....

.....

.....

(Total for Question 17 = 8 marks)

DO NOT WRITE IN THIS AREA

DO NOT WRITE IN THIS AREA

DO NOT WRITE IN THIS AREA



DO NOT WRITE IN THIS AREA

DO NOT WRITE IN THIS AREA

DO NOT WRITE IN THIS AREA

18 A Mangonel is a type of catapult used to launch projectiles such as rocks. A student made a working model of a Mangonel.

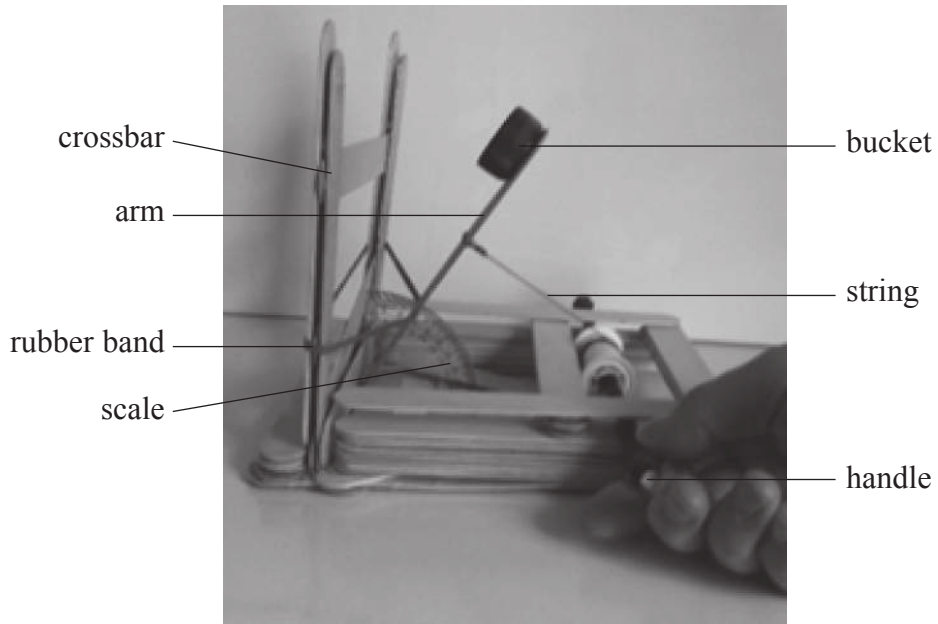

As the handle is turned, the arm is pulled back by the string. This increases the tension in the rubber band. When the string is released, the rubber band causes the arm to move upwards, launching a projectile from the bucket when the arm hits the crossbar.

(a) (i) Suggest why a rubber band is used to support the arm. (1)

.....

.....

(ii) State the energy transfers that occur when the string is released. (1)

.....

.....



- (b) The student varied the angle to the vertical at which the arm was released.
The range of the projectile was measured for each angle.

Release angle to the vertical / °	15	30	45	60
Mean range / m	0.14	0.58	0.95	1.70

- * (i) Explain why the range increases as the angle increases.

(4)

- (ii) The student replaces the projectile with one of a smaller mass.

State why this increases the range of the projectile.

(1)

- (iii) Suggest one modification to the model that would also increase the range of the projectile. Give a reason for your answer.

(2)

Modification

Reason



(c) The student wishes to place a target in the path of the projectile. The height of the target is 5.0 cm. The projectile is released horizontally from a height of 13.0 cm.

(i) Show that the time taken for the projectile to fall to a height of 5.0 cm is about 0.1 s.

(2)

(ii) When the arm was pulled back through an angle of 60° , the time taken for the projectile to travel 1.7 m horizontally was 0.16 s.

Calculate the minimum horizontal distance that the target should be placed from the model for the projectile to hit it.

(3)

Minimum horizontal distance =

(Total for Question 18 = 14 marks)



19 (a) A lorry gradually accelerates from rest. There is a box of mass 200 kg on the back of the lorry. The box is not tied to the lorry.

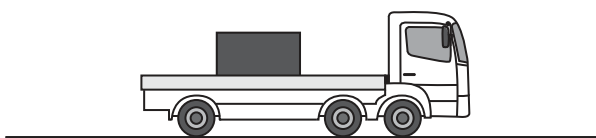

(i) The lorry accelerates from rest to a speed of 15 m s^{-1} over a distance of 39 m.

Show that the acceleration of the lorry is about 3 m s^{-2} .

(2)

.....

.....

.....

.....

(ii) The maximum frictional force between the lorry and the box is 630 N.

Explain why this limits the maximum acceleration that the lorry can have without the box falling off. Your answer should include a calculation.

(3)

.....

.....

.....

.....

.....

.....

.....



- (b) Once the lorry has reached its destination, the back of the lorry is tilted at an angle θ to the horizontal.

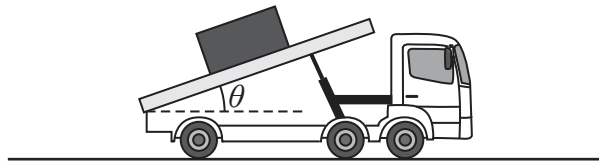

Three forces act on the box: the weight W , the normal contact force R and the frictional force F .

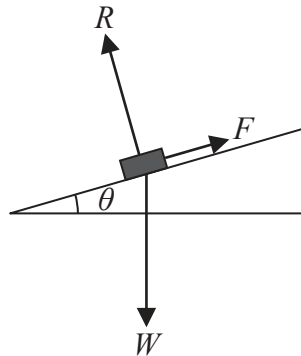

- (i) State expressions for the components of the weight of the box parallel to the back of the lorry and perpendicular to the back of the lorry.

(2)

$$W_{\text{parallel}} = \dots\dots\dots$$

$$W_{\text{perpendicular}} = \dots\dots\dots$$

- (ii) The angle θ is increased until the box is just about to slide.

Given that $F = 0.32R$, calculate the value of θ at which the box is just about to slide.

(4)

$$\theta = \dots\dots\dots$$

(Total for Question 19 = 11 marks)

TOTAL FOR SECTION B = 70 MARKS
TOTAL FOR PAPER = 80 MARKS



List of data, formulae and relationships

Acceleration of free fall	$g = 9.81 \text{ m s}^{-2}$	(close to Earth's surface)
Electron charge	$e = -1.60 \times 10^{-19} \text{ C}$	
Electron mass	$m_e = 9.11 \times 10^{-31} \text{ kg}$	
Electronvolt	$1 \text{ eV} = 1.60 \times 10^{-19} \text{ J}$	
Gravitational field strength	$g = 9.81 \text{ N kg}^{-1}$	(close to Earth's surface)
Planck constant	$h = 6.63 \times 10^{-34} \text{ J s}$	
Speed of light in a vacuum	$c = 3.00 \times 10^8 \text{ m s}^{-1}$	

Unit 1

Mechanics

Kinematic equations of motion	$v = u + at$ $s = ut + \frac{1}{2}at^2$ $v^2 = u^2 + 2as$
-------------------------------	---

Forces	$\Sigma F = ma$ $g = F/m$ $W = mg$
--------	------------------------------------

Work and energy	$\Delta W = F\Delta s$ $E_k = \frac{1}{2}mv^2$ $\Delta E_{\text{grav}} = mg\Delta h$
-----------------	--

Materials

Stokes' law	$F = 6\pi\eta rv$
-------------	-------------------

Hooke's law	$F = k\Delta x$
-------------	-----------------

Density	$\rho = m/V$
---------	--------------

Pressure	$p = F/A$
----------	-----------

Young modulus	$E = \sigma/\epsilon$ where Stress $\sigma = F/A$ Strain $\epsilon = \Delta x/x$
---------------	--

Elastic strain energy	$E_{\text{el}} = \frac{1}{2}F\Delta x$
-----------------------	--

DO NOT WRITE IN THIS AREA

DO NOT WRITE IN THIS AREA

DO NOT WRITE IN THIS AREA



DO NOT WRITE IN THIS AREA

DO NOT WRITE IN THIS AREA

DO NOT WRITE IN THIS AREA

BLANK PAGE



DO NOT WRITE IN THIS AREA

DO NOT WRITE IN THIS AREA

DO NOT WRITE IN THIS AREA

BLANK PAGE

